

OPERATION MANUAL
VOLTAGE
REMOTE CONTROLLER
MODEL 874S
(SPEC89815)

First Edition

WARNINGS against **HIGH VOLTAGE**

- o *Model 874S generates high voltage, combined with Model 871S.*
- o *Any incorrect handling may cause death.*
- o *Read Section 3 "WARNINGS" in this manual to prevent accident.*
- o *This manual should be placed within the reach of the operator so that he may read it whenever necessary.*

KIKUSUI ELECTRONICS CORPORATION

90.3.9

902800

Power Requirements of this Product

Power requirements of this product have been changed and the relevant sections of the Operation Manual should be revised accordingly.

(Revision should be applied to items indicated by a check mark)

Input voltage

The input voltage of this product is _____ VAC,
and the voltage range is _____ to _____ VAC. Use the product within this range only.

Input fuse

The rating of this product's input fuse is _____ A, _____ VAC, and _____.

WARNING

- To avoid electrical shock, always disconnect the AC power cable or turn off the switch on the switchboard before attempting to check or replace the fuse.
- Use a fuse element having a shape, rating, and characteristics suitable for this product. The use of a fuse with a different rating or one that short circuits the fuse holder may result in fire, electric shock, or irreparable damage.

AC power cable

The product is provided with AC power cables described below. If the cable has no power plug, attach a power plug or crimp-style terminals to the cable in accordance with the wire colors specified in the drawing.

WARNING

- The attachment of a power plug or crimp-style terminals must be carried out by qualified personnel.



— To supervisor in charge of operation —

- (1) *If the operator does not read the language used in this manual, translate the manual into appropriate language.*
- (2) *Help the operator in understanding this manual before operation.*
- (3) *Keep this manual near the tester for easy access of the operator.*

— Receiving inspection —

Prior to the shipment from our factory, the tester has been subjected to electric- and mechanical-testing and guaranteed of satisfactory quality and performance. Nevertheless, you are kindly requested to make an acceptance inspection to see if the tester has any in-transit damage. Should there be any, please inform our local dealer of such a damage.

= ATTENTION =

Pay attention to the following instructions and those warnings given in the Section 3 "WARNINGS" as well.

Read Section 3 "WARNINGS" in Operation Manual of Model 871S.

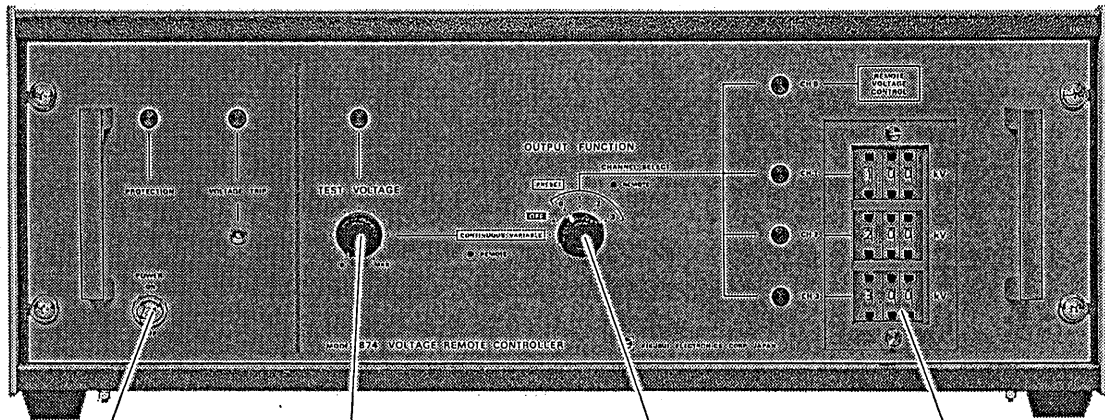

Before turning on the POWER switch, pay good attention to the setting on the peripheral device.

Check the preset voltage, before changing the setting on the OUTPUT FUNCTION.

Preset channels in unuse to "0".

TEST VOLTAGE dial should be at "0" position except during the testing.

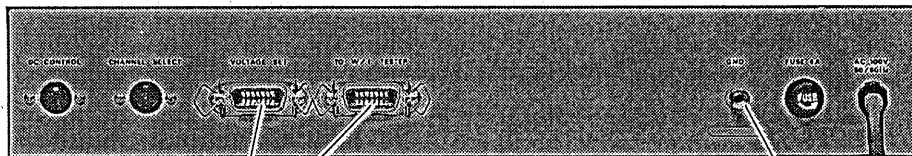

Turn off each power switch of the peripheral device when connecting or disconnecting the connector.

The rear-side of the tester casing and the protective grounding terminal shall be connected to the earth, using the applicable tool.

TABLE OF CONTENTS

	<u>PAGE</u>
1. GENERAL	1
2. SPECIFICATIONS	2
3. WARNINGS	5
4. OPERATION INSTRUCTIONS	11
4.1 Description of Front Panel	11
4.2 Description of Rear Panel	13
4.3 Operating Procedures and Notes	15
(A) Notes Before Test	15
(B) To Hook-up the 874S to the 871S	16
(C) Digital Setting of Test Voltage	16
(D) Continuously Variable Adjustment of Test Voltage	16
(E) VOLTAGE TRIP Function	17
(F) Remote Control	18
5. OPERATING PRINCIPLE	22
5.1 Block Diagram	22
5.2 Description of Blocks	22

902803

1 . GENERAL

Model 874S Voltage Remote Controller is used to remote-control the output voltage (dielectric strength test voltage) of Model 871S Withstanding Voltage/Insulation Resistance Tester. The 874S can be control the 871S output up to 3 kV, 20 mA.

The 874S has provisions to preset four different output voltages-- three with the digital switches on its front panel and one with an external signal. The preset voltages are selectable with the panel switch or with an external signal. Thus, the 874S allows to preset different test voltages for different device under test and to select the voltages as required, or to test a device under test with different voltages in one test cycle, thereby greatly improving the test efficiency and economizing the test labor.

The 874S also has a provision to control continuously variably the output voltage of the 871S.

The 874S has a sine wave generator and a power amplifier, with which to drive the high voltage transformer of the 871S, allowing it to generate a quality test voltage which is very less affected by line voltage change or waveform distortion.

2. SPECIFICATIONS

- (1) Model 874S Remote Controller is used to control the output voltage (withstanding strength test voltage) of Model 871S Tester. The output voltage of the tester can be controlled as follows:

Maximum Output

3 kV, 10 mA: For up to 60 seconds of continuous operation, requiring a pause period of twice of operation period before each run

3 kV, 20 mA: For up to 5 seconds of continuous operation, requiring a pause period of 5 times of operation period before each run

- (2) Digital Setting of Output Voltage

Setting Range: 0.20 - 3.00 kV

No. of Channels: Total four channels
(Three channels can be set with digital switches on controller panel; one channel can be set with remote BCD signal.)

Setting Accuracy: $\pm(1\%$ of set value + 1 digit)

Channel Select: With panel switch or remote signal

Note 1: To remote-control the test voltage setting or the channel select setting, the corresponding pin of the remote control connector must be driven to the LOW ACTIVE status in one of the following methods:

- ① By using a make-contact (such as relay or switch)
- ② By using a logic circuit.

The conditions of input for the equipment are as follows:

HI level input voltage: 11 - 15 V
LO level input voltage: 0 - 4 V
LO level sweep out current: 1 mA or less

902805

Note 2: To satisfy the above-mentioned setting accuracy, Model 874S Remote Controller and Model 871S Tester connected together must be calibrated as an integrated system.

(3) Continuously Variable Control of Output Voltage

- With panel control (The output voltage is uncalibrated.)
- With external DC voltage signal

Signal and output: 0 - 10 V DC signal for output voltage 0 - 3 kV AC

Setting accuracy: $\pm(1\% \text{ of set value} + 10 \text{ V})$, for 0.2 - 3 kV

(4) Load Regulation

Better than 1%, for 20 mA to no load, at 3 kV output

(5) Output Voltage Trip

To limit the output voltage at a preset level

(6) Remarks: When the leak current detect reference value of Model 871S Tester is set at 21 mA or more, the output voltage cannot be remote controlled with Model 874S Remote Controller and must be manually controlled with the panel control of Model 871S tester.

(7) Environment

Ambient Temperature and Humidity

Specification range: 5 to 35°C, 20 to 80% RH

Operable range: 0 to 40°C, 20 to 80% RH

Power Requirements

Line voltage: 240 V $\pm 10\%$, 50/60 Hz AC
(This model can correspond to nominal voltages 110V, 115V, 120V, 220V, 230V and 100V respectively, subject to prior modification.)

902806

Power consumption

When no load : Approx. 40 VA
(RESET state)

When with 3 kV, 20 mA load: Approx. 130 VA

Insulation resistance: 30M Ω or more, with 500 V DC

Withstanding voltage: 1000 V AC, 1 minute

(8) Dimensions: 497 W \times 180 H \times 370 D mm

 Including extrusions: 500 W \times 195 H \times 410 D mm

Weight: Approx. 21 kg

(9) Accessories: 8P DIN cable, 1
 14P Amphenol cable, 1
 14P Amphenol plug, 1
 5P DIN cable, 1
 Operation Manual, 1 copy

902807

3. WARNINGS

Model 874S supplies high voltage up to 3kV to the outside connection, combined with Model 871S.

Thus any incorrect handling of the tester may bring the risk of death to the operator. For safe operation of the tester, strictly observe the following instructions.

(In this section, "Tester" means the 871S Withstanding Voltage/Insulation Resistance Test System, including Model 874S.)

1. Electrification

Be sure to wear a pair of rubber gloves for electrical job, before operating the tester, to prevent electric shock.

2. Grounding:

The protective grounding terminal, on the rear of the tester casing, shall be positively grounded using the applicable tool.

If not properly grounded, the casing of this tester is charged with high voltage when the power is short-circuited to the ground or conveyer or any devices connected to the ground or to the commercial power line (Note i).

It is very risky that anyone who touches the casing under such a condition will be subject electric shock.

(Note i) Generally a commercial power line means a line leading to the AC cord socket of the tester, from which the rated power is supplied into the tester.

This manual also covers the power supply line from a private power generator.

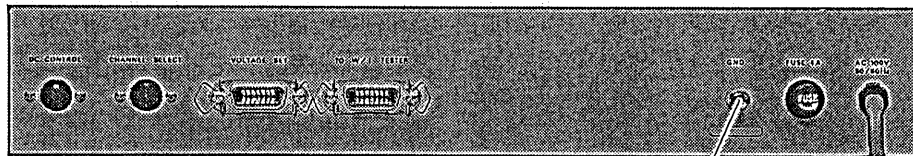

Protective grounding terminal

Figure 3.1 Rear of Casing, Model 874S

3. Connection to Model 871S

Model 874S is operated in combination with Model 871S. So, for the connection of this Model to Model 871S, carefully read Section 3 "WARNINGS" of Model 871S operation manual.

Furthermore, for cable connection to Model 871S, turn OFF, in advance, the respective power switches of both Models and turn the TEST VOLTAGE dial to the extreme left ("0" position).

4. Power source switch:

The power switch shall be turned on after confirming the following three items.

- The TEST VOLTAGE dial of Model 874S has been turned to the extreme left ("0" position).
- The OUTPUT FUNCTION knob of Model 874S is "OFF."
- The TEST VOLTAGE dial of Model 871S has been turned to the extreme left ("0" position).

5. Change of test condition:

Change-over of the switches on the panel of Model 874S & 871S shall be made after confirming that the RESET button of Model 871S has been pushed in and that the TEST VOLTAGE dial of Model 874S & 871S has been turned to the extreme left ("0" position).

- 5.-1) The 874S remotely dictates the hazardously high output voltage of the 871S. If you carelessly operate the 874S, hazards can result. Operate very carefully the digital switches (voltage presetting switches) and the CHANNEL SELECT switch (preset voltage select switch) on the front panel of the 874S.

Operate still more carefully the test setup when presetting the output voltage with an external BCD signal or selecting preset voltages with an external select signal in a remote control mode.

- 5.-2) The 874S has four channels to preset four different test voltages (output voltages of the 871S). The three of them can be preset with the digital switches on the front panel of the 874S and the remaining one can be preset with an external BCD signal. The preset test voltages are selectable with the panel switch or with an external signal.

If you select wrong channels, wrong test voltages will be delivered. With a view to minimize the hazards to the operator or damage to the device under test, preset the test voltages of the unused channels at zero volts.

- 5.-3) The 874S has a selector switch (the OUTPUT FUNCTION selector switch on the front panel) with which to select either one of the digitally preset voltages or the continuously variable output voltage control mode (analog control mode) in which the output voltage is continuously variable with the TEST VOLTAGE dial on the front panel.

Wrong test voltages will be delivered if you operate the selector switch wrongly by mistake. This can result in hazards to the operator or in damage to the device under test.

With a view to minimize this type of hazards or damage, set the digital switches and the TEST VOLTAGE dial at zero volts so far as they are not actually being used.

- 5.-4) The maximum rated output current of the 874S is 20 mA (for 5 seconds) in terms of the output current of the 871S. When the leakage current detect reference value is set at 21 mA or more by the 871S, the test voltage is controlled not remotely by the 874S but is locally controlled by the TEST VOLTAGE dial of the 871S. When the reference value is changed from 20 mA or less to 21 mA or more, the test voltage as set by the TEST VOLTAGE dial of the 871S is delivered.

If the test voltage is set at a high voltage, hazards and damage can be caused when the reference value is carelessly changed as above.

With a view to minimize such hazards and damage, set the TEST VOLTAGE dial of the 871S at the zero position (fully counterclockwise position) so far as this dial is not being used for test voltage control.

902810

5.-5) On the contrary to the above, if the leakage current detect reference value is changed to 20 mA or less from the state that the reference value is set at 21 mA or more and the test voltage is controlled locally by the TEST VOLTAGE dial of the 871S, control of the test voltage is transferred from the 871S to the 874S and the test voltage changes to that set by the digital switches or the TEST VOLTAGE dial of the 874S. With a view to minimize hazards and damage which could be caused by careless change of the leakage current detect reference value, set the digital switches and the TEST VOLTAGE dial of the 874S at zero volts so far as they are not being used.
Be prudent enough when changing the reference value.

5.-6) As mentioned in 5.-4) and 5.-5), control is transferred between the 874S and the 871S depending on whether the leakage current detect reference value is 20 mA or less or it is 21 mA or more. Thus, change of the reference value at this point has a special meaning. To alert the operator to this change, the TEST VOLTAGE REMOTE lamp of the 871S blinks.

6. Suspension of testing:

Except under testing, the TEST VOLTAGE dial of Model 874S & 871S shall be turned to the extreme left("0" position), and be "OFF" the OUTPUT FUNCTION knob of Model 874S.

Also, push the RESET button (H.V OFF) of Model 871S to ensure safety. The Power switch shall be turned off if the tester is not used for some time or the operator is to leave from the tester.

7. Remote control of tester:

In the case Model 874S is to be remote controlled, the application of high voltage to Model 871S will be controlled by an external signal.

Take the following safety precautions to prevent accident. Also, shall be maintained the safety precaution under positive control.

- NOT to permit unexpected output of high voltage from the tester (that is, to prevent this tester from being put in TEST ON condition).
- NOT to permit operator and any other come into contact with D.U.T. test lead-wire, probe, output terminal, etc. while the tester is generating high test voltage.

8. Re-turn on of POWER switch:

Once the Power switch has been turned off, be sure to turn it on again, after a few seconds.

Cutting off and throwing in the power switch as high voltages is kept output is dangerous, because, if do so, high voltage output condition will continue occasionally. Therefore, avoid doing so.

— In case of Emergency —

9. Emergency handling:

In the case of any accident such as an electric shock or burn-down of the D.U.T. resulting from the failure of the tester or D.U.T., take the following actions promptly;

- cut off the POWER switch of Model 874S, and
- pull out the plug of AC cord of Model 874S from the socket of the power source, and
- cut off the POWER switch of Model 871S, and
- pull out the plug of AC cord of Model 871S from the socket of the power source.

It dose not make any difference whichever action of the above four is taken first, but be sure to take the four actions.

— Trouble-shooting —

10. In case of trouble:

In the following cases of trouble, it is very hazardous.

Model 874S may possibly encounter a critical trouble.

- When Model 871S is NOT in protection even after "OUTPUT FUNCTION" knob was turned OFF.
- When the preset voltage is different from the indicated voltage on the output voltmeter of Model 871S.

The immediate action to take, in the above cases, is to pull out the plug of AC cord from the the socket of the power source, and suspend the operation of the tester.

Thereafter, entrust us with the trouble-shooting and repair of your defective tester.

11. PROTECTION lamp:

If the PROTECTION lamp of the 874S illuminates in spite of that it is being operated within its heat dissipation capacity, there is another reason (such as a circuit failure of the 874S). Immediately stop operating the 874S and do not use it until the cause of the failure is remedied.

◆◆ Attention for Trouble-Free Operation ◆◆

12. The heat dissipation capacity of the 874S is one-sixth of that for continuous operation with its maximum ratings. (The 874S is designed with this over-rating from the viewpoints of size, weight and economy.) Therefore, the 874S can deliver its maximum output only for short periods (see Section 2 "SPECIFICATIONS").

The periods, however, are as the 874S is operated in the most unfavorable conditions that the output voltage is approximately 0 V, output current 20 mA, ambient temperature 40°C, and line voltage 110 V. When the operating conditions are more favorable, the allowable operating periods become longer.

If the 874S is operated beyond its heat dissipation capacity, the protector trips, the output is cut off, and the PROTECTION lamp on the 874S and that on the 871S illuminate. When this has occurred, stop operating the equipment until it is cooled off and the PROTECTION lamps go off.

13. If the PROTECTION lamp of the 874S illuminates in spite of that it is being operated within its heat dissipation capacity, there is another reason (such as a circuit failure of the 874S). Immediately stop operating the 874S and do not use it until the cause of the failure is remedied.
14. Do not use or store the 874S in high temperature (direct sunlight), high humidity, dusty atmosphere, or other unfavorable environments.

902813

4. OPERATION INSTRUCTIONS

4.1 Description of Front Panel

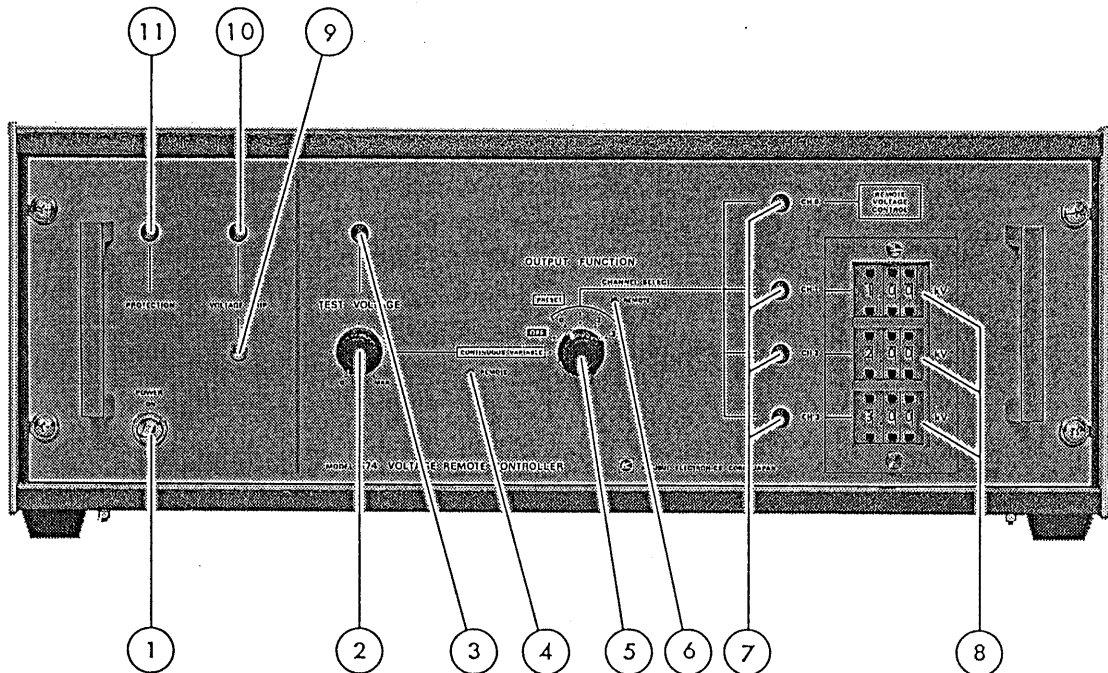

Figure 4.1 Front Panel

① POWER ON/OFF Switch:

Main power switch of the 874S. Before turning on the switch, be sure to read Section 3 "WARNINGS."

② TEST VOLTAGE Dial:

The dial controls continuously variably the test voltage. The test voltage increases as you turn the dial clockwise.

When the REMOTE lamp ④ is illuminating, however, the dial is disabled and the test voltage is remote-controlled with an external DC signal.

③ TEST VOLTAGE Lamp:

The lamp illuminates to indicate that the TEST VOLTAGE dial is enabled.

412606

④ REMOTE Lamp:

The lamp illuminates to indicate that the test voltage is being remote-controlled by an external DC signal.

⑤ OUTPUT FUNCTION Selector Switch:

The switch allows to select either the analog control mode or the digital control mode for the test voltage. When in the analog mode (the CONTINUOUSLY VARIABLE mode), the test voltage can be controlled with the CONTINUOUSLY VARIABLE dial on the front panel of the 874S. When in the digital control mode, the switch allows further to select one of the four output voltage digitally preset with four channels of 0 - 3. When the switch is set to the OFF position, the 874S sends a PROTECTION signal to the 871S making it disabled to be driven into the TEST ON state.

⑥ REMOTE Lamp:

The lamp illuminates to indicate that channel selection for the test voltage is made with the external signal and the OUTPUT FUNCTION selector switch is disabled.

⑦ CH0 - CH3 Lamps:

The illuminating one of the lamps indicates the selected one of the four digitally preset test voltage channels of 0 - 3. The test voltage of CH0 is preset with an external BCD signal. Those of CH1 - CH3 are preset with respective digital switches. And read page 7, item 5.-2).

⑧ Digital Switches:

The digital switches preset the test voltages of the respective channels.

⑨ VOLTAGE TRIP Control:

The control is a screwdriver adjusting type of potentiometer which sets the maximum test voltage. When the output voltage of the 871S has become higher than the voltage set with this control, the output voltage

902815

is cut off in order to protect the Device Under Test, regardless of the presetting methods of the test voltages.

⑩ VOLTAGE TRIP Lamp:

The lamp illuminates to indicate that the VOLTAGE TRIP function has been brought into effect. When in this state, the 874S sends a PROTECTION signal to the 871S, disabling it to deliver its output voltage.

⑪ PROTECTION Lamp:

The lamp illuminates to indicate that one of the protectors incorporated in the 874S has tripped. If the lamp illuminates due to other cause than that described in Section 3, item 11., immediately stop using the 874S since the illuminating lamp means that the 874S has failed. When the lamp is illuminating, the 874S sends a PROTECTION signal to the 871S thereby disabling the 871S to be driven into the TEST ON state.

4.2 Description of Rear Panel

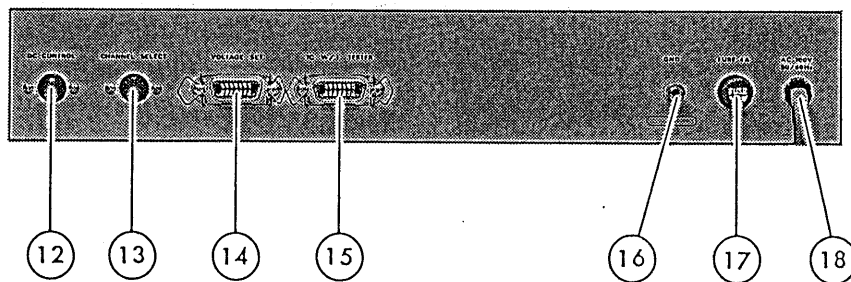

Figure 4.2 Rear Panel

⑫ DC CONTROL Connector:

The connector accepts an external DC voltage signal with which to control the test voltage.

902816

⑬ CHANNEL SELECT Connector:

The connector accepts an external signal with which to select the pre-set test voltage channels.

⑭ VOLTAGE SET Connector:

The connector accepts an external BCD signal with which to set the test voltage.

⑮ TO W/I TESTER Connector:

The connector is to connect the 874S to the 871S.

⑯ Protective GND Terminal:

The terminal is to ground the 874S to the earth.

⑰ Fuse:

AC line fuse

Nominal voltage	Fuse
100 V, 110 V	4 A
115 V, 120 V	
200 V, 220 V	2 A
230 V, 240 V	

⑱ AC XXXV 50/60 Hz Cord:

AC line input power cord

902817

4.3 Operating Procedures and Notes

(A) Notes Before Test

- (1) When the 874S is remote-controlling the output voltage of the 871S for withstanding voltage test, the output voltage can be controlled irrespective of setting of the W TEST RANGE 1.5kV/3kV selector switch on the front panel of the 871S. However, the scale of the output voltmeter is as selected locally by the switch. Therefore, the switch should normally be set at the 3kV range and should be changed to the 1.5kV range only when it is needed by the 874S.
- (2) When in any of the following cases, the 874S sends the PROTECTION signal to the 871S to cut out its output voltage. To start or resume test, press the RESET button to reset the equipment.
 - (a) When the POWER switch of the 874S is turned on
 - (b) When the OUTPUT FUNCTION selector switch is set to the OFF position
 - (c) When the CONTINUOUS VARIABLE mode of operation is changed from the local control to the remote control or in the reverse
 - (d) When channels are changed in the PRESET mode
 - (e) When channel setting is changed from local to remote or in the reverse.
 - (f) When the VOLTAGE TRIP function is brought into effect.

Also when in one of the following cases, the 874S sends the PROTECTION signal to the 871S. When this has occurred, the PROTECTION lamp on the front panel of the 874S illuminates either for a definite period or an indefinite period as follows:

- (a) When the heat dissipation capacity of the 874S is exceeded. The equipment is reset as it is cooled off, and the lamp goes out.
- (b) When a failure whatever has occurred in the 874S. In this case the 874S goes on sending the PROTECTION signal and the lamp goes on illuminating.

- (3) The maximum output current of the 874S is 20 mA (for 5 seconds) in terms of the output current of the 871S. When the reference value for leak current detection is preset at 21 mA or over in Model 871S, Model 874S is not available for the use. In such a case, the operation mode of Model 871S is automatically changed to local control mode. So, turn the test voltage knob of Model 871S to extreme left ("0" position). Thereafter, re-preset an intended test voltage using the test voltage dial of Model 871S.

(B) To Hook-up the 874S to the 871S

Connect the W/I TESTER connector of the 874S to the VOLTAGE REMOTE CONTROLLER connector of the 871S.

(C) Digital Setting of Test Voltage

- (1) Three different test voltages can be preset with the digital switches of CH1 - CH3.
- (2) As you select one of CH1 - CH3, the test voltage of the selected channel is specified as the test voltage.
- (3) As you set the 871S to the TEST ON state in the withstanding voltage test mode, the 871S delivers the test voltage selected as above.

(D) Continuously Variable Adjustment of Test Voltage

- (1) Set the OUTPUT FUNCTION selector switch to the CONTINUOUSLY VARIABLE position.
- (2) Turn the TEST VOLTAGE dial to the fully counterclockwise position ("0" position). Set the 871S to the TEST ON state. Now the test voltage (output voltage of the 871S) is adjustable with the TEST VOLTAGE dial.

Note: Whenever the TEST VOLTAGE dial is not used for test, set it at the fully counterclockwise position ("0" position).

902819

(E) VOLTAGE TRIP Function

- (1) While the maximum output voltage the 874S can deliver is 3 kV, an output voltage limit can be set with the VOLTAGE TRIP function for the sake of safety. It is most recommendable to set the limit at a voltage slightly higher than the highest voltage used for usual tests. To set the limit voltage, proceed as follows:
 - (a) Set one of the digital switch channels at a voltage higher by 5 - 10% than the highest voltage used for usual tests. Select the channel with the CHANNEL SELECT switch.
 - (b) Gradually turn counterclockwise the VOLTAGE TRIP control (screw-driver adjustment type of potentiometer) from the clockwise extreme position until the yellow lamp above the control illuminates.
 - (c) Leaving the control at the above position, gradually lower the voltage set by digital switches of the corresponding channel until the lamp goes out. The voltage at which the lamp has gone out is the value set by the control for the output voltage limit. If the value set thus is not close enough to the desired limit voltage, repeat the setting procedure.
- (2) Regardless of the operating mode of the 874S, the output voltage is limited by the voltage set as above. No output voltage higher than this can be delivered as the VOLTAGE TRIP function is brought into effect if such is attempted. The function remains enabled even when the leakage current detect reference value of the 871S is set at 21 mA or more or when the output voltage is controlled by the TEST VOLTAGE dial on the front panel of the 871S.
- (3) During the period the VOLTAGE TRIP lamp is illuminating, the 874S sends the PROTECTION signal to the 871S and it is disabled to be driven into the TEST ON state. The 871S cannot be reset from the disabled state by pressing its RESET button. If you need a test voltage higher than that currently set for the VOLTAGE TRIP function, raise the voltage setting. As you do this, the lamp will go out and the RESET button will be enabled.

902820

(F) Remote Control

The various presettings in Model 874S can be remote-controlled. With this remote-control, ON/OFF control of high voltage output from Model 871S is also available. Read the precautions in remote-controlled operation on page 8, Section 3, item 7 to prevent accident.

(1) Remote Control of CHO Test Voltage

By setting the CHANNEL SELECT switch to CHO, the test voltage can be set with an external BCD signal. (When the switch is set to CH1 - CH3, test voltage can be preset with the digital switches of respective channels.) The BCD signal can be applied through the VOLTAGE SET connector, of which pin assignment and layout are shown below.

- The BCD signal is of a LOW active type.
- Connect the required pins to the common line via relay contacts, transistors or other switching devices. Each of the pins is pulled up to the +15V supply voltage through a resistor of 22 k Ω or higher.
- The method of connecting the pins to the common line is identical with that for remote control of the 871S.
- The engineering unit of measure of the BCD signal is "kV".

Connector Name: VOLTAGE SET

Pin No.	Use of Pin	
1	1	10 ⁻² column
2	2	
3	4	
4	8	
5	1	10 ⁻¹ column
6	2	
7	4	
8	8	
9	1	10 ⁰ column
10	2	
11	4	
12	NC (no connection)	
13	NC (no connection)	
14	COM (common)	

162600

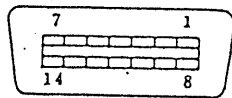

Figure 4.3 Layout of VOLTAGE SET Connector Pins (as viewed from chassis rear)

One of the recommended ways of use is to prepare a 14-pin plug whose required pins are connected to the COM pin (pin No.14) for a voltage which is frequently used for tests. The voltage of CHO can be rapidly set by connecting the plug to the VOLTAGE SET connector. Thus, test voltages for four channels (CH1 - CH3 with the digital switches on the front panel plus CHO) can be preset.

(2) Remote Control of Channel Select Function

The channel select function of the 874S can be remote-controlled with signals fed via the CHANNEL SELECT connector, disabling the local CHANNEL SELECT switch. The assignment of the connector pins are as shown below.

Connector Name: CHANNEL SELECT

Pin No.	Pin Assignment	Remarks
1	2^0	Channel can be specified with a Low active binary code signal
2	2^1	
3	CHANNEL R/L	Remote/Local select. (When in the remote mode, the pin must be in the LOW status.)
4	COM (common)	
5		NC (no connection)
6		
7		
8		

Notes: (a) Set the OUTPUT FUNCTION selector switch to one of PRESET 0 - 3.

(b) For the connector pin layout, see Figure 4.4.

(c) To select the remote mode, connect pin No.3 to the COM line. To select the local mode, make pin No. 3 open.

Thus, the test voltage can be readily remote-controlled by presetting different voltages for the different channels and remotely selecting the preset voltages.

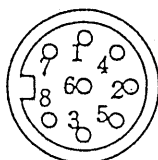

Figure 4.4 Layout of CHANNEL SELECT Connector Pins
(as viewed from chassis rear)

(3) Remote Control of CONTINUOUSLY VARIABLE Function (DC CONTROL Function)

The test voltage can be remote-controlled continuously variably by applying external DC signal via the DC CONTROL connector. For this mode of remote operation, proceed as follows:

- (a) Set the OUTPUT FUNCTION selector switch to the CONTINUOUSLY VARIABLE position.
- (b) Apply a DC control signal via the DC CONTROL connector. The connector pin assignment is as shown in the following table.

Connector Name: DC CONTROL

Pin No.	Pin Assignment	Remarks
1	+11V SUPPLY	Provides a supply voltage of approximately +11 V. Current rating 0.5 mA
2	DC IN	Accepts a DC control input signal. Input impedance approximately 1 MΩ
3	VOLTAGE COM	Common line for DC control input signal
4	DC CONTROL R/L	Accepts remote/local select signal (contact signal: made for remote and broken for local).
5	R/L COM	Common line for remote/local select signal

Notes: (a) The output voltage (0 - 3 kV) is proportional to the DC control voltage (0 - 10 V).

The control accuracy is $\pm(1\%$ of set voltage +10 V) within an output setting of 0.2 - 3 kV.

(b) The +11V supply may be used to obtain a DC control voltage using a potentiometer as shown in Figure 4.5. The output impedance of the voltage supply is approximately 1 kΩ.

902823

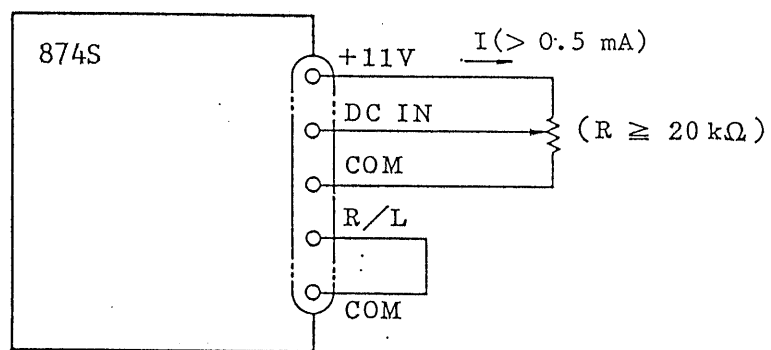

Figure 4.5 An Setup for DC CONTROL with +11V Supply



Figure 4.6 Layout of DC CONTROL Connector Pins (as viewed from chassis rear)

902824

5. OPERATING PRINCIPLE

5.1 Block Diagram

A block diagram of the 874S is shown in Figure 5.1.

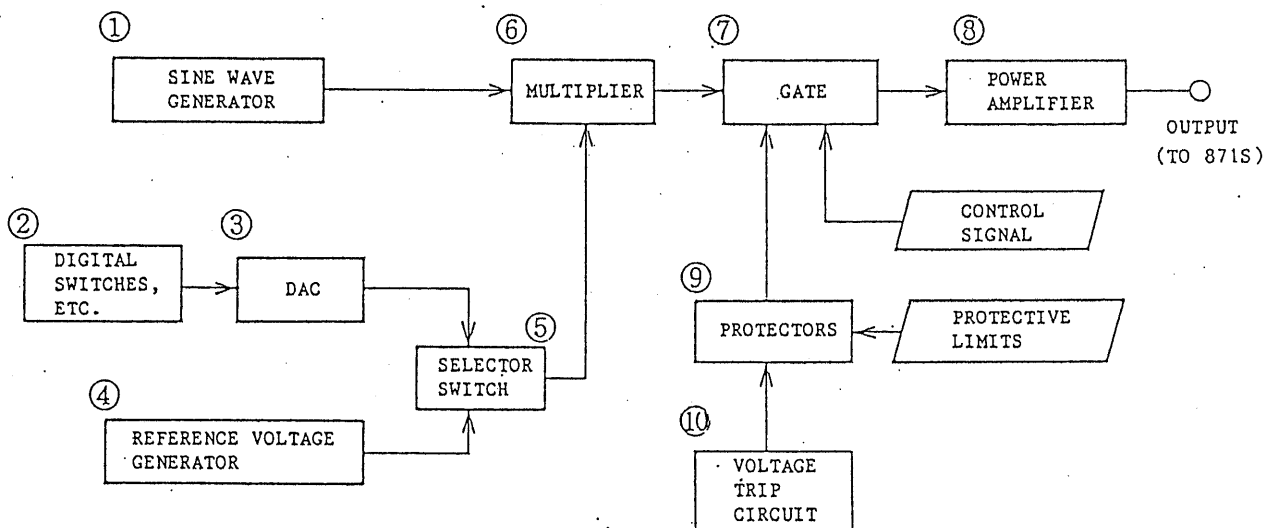

Figure 5.1

5.2 Description of Blocks

The functions of individual blocks of the 874S are described below.

(1) Sine Wave Generator

Provides a waveform reference signal for the test voltage. The signal is of a quality sinusoidal waveform synchronized with the line frequency, obtained by feeding the line voltage through a 12-dB/oct low pass filter to eliminate harmonics.

(2) Digital Switches, etc.

This block sets and processes the digital switch signals to preset locally test voltages and processes the BCD signal to preset remotely a test voltage.

(3) DAC

Converts the digital signal processed as above into a DC analog signal.

(4) Reference Voltage Generator

Provides a DC voltage signal which is used as a voltage reference for generating a test voltage in the CONTINUOUS VARIABLE mode.

(5) Selector Switch

Selects the reference voltage for the preset digital mode or for the continuously variable analog mode.

(6) Multiplier

Multiplies the DC reference signal by the waveform reference signal and delivers a sine wave of a controlled voltage which is used as a test voltage reference signal.

(7) Gate

Passes or stops the test voltage reference signal.

(8) Power Amplifier

Amplifies the test voltage reference signal to a power level sufficient to drive the high voltage transformer of the 871S.

(9) Protectors

Provide various protective functions for the safety of test. But be careful to operate.

(10) Voltage Trip Circuit

Allows to limit the maximum test voltage, preventing delivery of unnecessary high voltage.

962200